

Operating Instructions

VETTER Pipe and Test Sealing Bags



Contents

1. Introduction	4
1.1 Symbols used.....	4
1.2 Correct handling and usage.....	4
2. Safety instructions	5
2.1 General information	5
2.2 Information about the dangers.....	6
2.3 Warnings.....	6
3. Operation of Pipe and Test Sealing Bags	7
3.1 Operation with controller, inflation hose and compressed air bottle	7
3.2 Operation with controller, inflation hose and other compressed air sources	8
3.3 Operation with a foot pump having a safety valve	9
4. Operation of Pipe and Test Sealing Bags	9
4.1 Preparations for operation	9
4.2 Support structure.....	10
4.3 Blocking a pipeline	11
4.4 Emptying the pipeline	12
4.5 Water test and compressed air test	12
4.6 Water pressure test (open channel).....	12
4.7 Compressed air test.....	13
4.8 Construction of a temporary bypass.....	14
5. Care, maintenance and storage.....	14
5.1 Care.....	14
5.2 Maintenance intervals	15
5.3 Storage.....	16
6. VETTER Round Profiles	17
6.1 Vetter Mini Pipe Sealing Bags 2.5 bar	17
6.2 VETTER Mini Test Sealing Bags 2.5 bar.....	18
6.3 Vetter Pipe Sealing Bags 0.5, 1.5 and 2.5 bar	19
6.4 Vetter Test Sealing Bags 0.5, 1.5 and 2.5 bar	21
6.5 Vetter Bypass Bags 1.5 bar.....	23
6.6 Vetter House connection Testing system 2.5 bar	24

6.7	Vetter Test Sealing Bags for Gullies 1,0 bar	25
6.8	Vetter Pipe Sealing Bags CR	26
6.9	Vetter High Pressure Pipe Sealing Bags 6 bar.....	27
7. VETTER Egg Profiles		
7.1	Vetter Egg Profile Bags 1 & 1.5 bar	28
7.2	Vetter Egg Profile Testing and Bypass bags 1 & 1.5 bar.....	29
8. Counter-pressure tables.....		
9. Material and resistance charts		
9.1	Material list.....	34
9.2	Temperature resistance	34
9.3	Resistance chart	35

Important information

1. **Owing to an increase in demand, all pipe and test sealing bags will be fitted with brass couplings as a standard from 01.01.2012 onwards.**

If you still wish to have the safety couplings (blue at 1.5 bar, black at 2.5 bar), we kindly ask you to state this explicitly when placing an order.

2. **The air has been completely suctioned out of the sealing pad to simplify shipping.**

However, the pad must **NOT be stored in this condition.**

When you unpack the pad, put the venting nipple on the coupling to allow air to penetrate back in. That lets the pad obtain its normal cylinder shape again.

If necessary, fill the pad with additional compressed air, but only to the point that it obtains its normal shape.

1. Introduction

The precondition for the safe use and the defect-free operation of Vetter pipe and test sealing bags is the knowledge and the observance of this operating manual as well as the safety instructions.

DIN 7716 is to be adhered to in cases of long-term storage.

In addition to this, the pertinent work protection regulations, work safety regulations and accident prevention regulations are to be observed the same as the generally recognized technology laws.

The operating instructions given here are to be regarded as part of the product and are to be kept for the complete life duration of the product. In case the product should be passed on to a successive user then the operating instructions must also be included.

1.1 Symbols used

The following symbols are used in the text for dangers and warnings:



This symbol means that there is imminent danger. If it is not avoided then death or serious injury will result.



This symbol means that there is a possible dangerous situation. If it is not avoided then death or serious injury could result.



This symbol means that there is possibly a dangerous situation. If it is not avoided then light injuries or slight injuries could result.



This symbol means that there is the possibility of damage being caused. If it is not avoided then the product or something else in its vicinity could be damaged.

1.2 Correct handling and usage

Vetter pipe and test sealing bags must, depending on the purpose of the task, only be inflated with compressed air to the corresponding pressure level using original inflation fittings.

Inflation with inflation fittings from another manufacturer is classified as contrary to the regulations for correct use.

They are exclusively used for blocking the intended pipes, for leak sealing testing of pipelines and for construction of a bypass.

Any other application or use going beyond this is classified as contrary to the regulations for correct use.

An application contrary to the regulations for correct use of Vetter pipe and test sealing bags includes:

- ✓ Incorrect use, operation or maintenance of pipe and test sealing bags.
- ✓ Use of the Vetter pipe and test sealing bags with defective safety devices or incorrectly fitted or non-functional inflation fittings.
- ✓ Non-observance of the instructions given in the operating manual concerning storage, operation and maintenance of pipe and test sealing bags.
- ✓ Insufficient monitoring of accessory parts subject to wear.
- ✓ Incorrectly carried out maintenance work.

Correct use according to regulations also includes

- ✓ The observance of all instructions given in this operating manual.
- ✓ The observance of the set periods for maintenance and care specified in the chapter „Maintenance and Care“.

2. Safety instructions

The knowledge and observance of this operating manual are the preconditions for the use of Vetter pipe and test sealing bags

2.1 General information

The observance of all pertinent work protection regulations and safety regulations, accident prevention regulations (e.g. safety regulations from the technical authorities – TBG) as well as the recognized technical laws are to be carried out.

The pipeline is to be inspected for damage before using pipe and test sealing bags. The area in the pipe for the pipe and test sealing bag must be free of deposits, dirt and foreign bodies, such as fragments, sharp-edged objects etc.

Necessary personal protection devices must be made available: protection clothing, gloves, helmets, facial and/or eye protection etc.

Pipe and test sealing bags must be positioned full length in the pipeline and with the sealing area on the inside wall of the pipe.

All pipe and test sealing bags (round and egg-shaped) must be non-positively and positively positioned and fitted.

 **DANGER**

 **DANGER**

 **DANGER**

 **WARNING**

 **WARNING**

2.2 Information about the dangers

Changes and modifications to the sealing bags, inflation fittings and inflation hoses are not permitted. Operation of Vetter pipe bags, test bags and bypass bags are only permitted with original Vetter inflation fittings and inflation hoses. Parts made by another manufacturer can influence safety.

Pipe and test sealing bags are made of a strong expanding material. If this material is expanded beyond its permitted maximum range then this can cause bursting. No person is allowed to remain within the working area during the pressure test. With a water pressure test, the pipeline being tested must not have any direct connection to a high-pressure line (e.g. hydrant).

After positioning the pipe and/or the test sealing bag it is to be ensured that nobody remain in the channel or in front of the pipe during inflation, as well as during the test procedure and emptying sequence. Before removing the set-up make certain that the pipeline is not under any pressure and is completely empty.

2.3 Warnings

The pipe and test sealing bags as well as the accessories must be checked for perfect condition before and after each operation. Outside the pipeline, Vetter pipe and test sealing bags, 0.5 bar and 1 bar, must only be filled to maximum 0.2 bar for the visual test. 1.5 bar and 2.5 bar bags must only be filled to a maximum of 0.5 bar.

All controllers are fitted with a safety valve that has a permitted maximum operating pressure corresponding to the pipe and test sealing bag. If the maximum operating pressure of 0.5, 1.5, 2.5 or 6 bar is exceeded then the safety valve will activate. The tolerance for opening and closing of the safety valve is only permitted to be a maximum of +/- 10 %. The set pressure must not be changed. If the sealing on the top part of the valve is removed then its operation is no longer guaranteed and the safety valve must be exchanged. The permitted inlet pressure on the controller (marking on the inlet coupling) must not be exceeded.

3. Operation of Pipe and Test Sealing Bags

This chapter informs you about which compressed air sources you can use with the Vetter pipe and test sealing bags.

Observe the corresponding pressure level with operation of pipe and test sealing bags



3.1 Operation with controller, inflation hose and compressed air bottle

Note! In the following presented figures the sequence of events uses the pressure level of 2.5 bar as an example. The corresponding bags and accessories must be used for other pressure levels and other sources of air.

Pipe and test sealing bags

- ✓ Step 1
Connect pipe and test sealing bags 2.5 bar to the inflation hose.

Inflation hose

- ✓ Step 2
Connect the inflation hose to the controller.

The inflation hose, the sealing bag and the controller must have the same pressure level.

Controller

- ✓ Step 3
Connect the connection hose of the pressure regulator to the inlet coupling of the controller. In doing this it is imperative that the permitted inlet pressure of the controller is observed

Pressure regulator

- ✓ Step 4
Screw-in the connection thread of the pressure regulator into the inside thread of the valve on the compressed air bottle.

Compressed air bottle

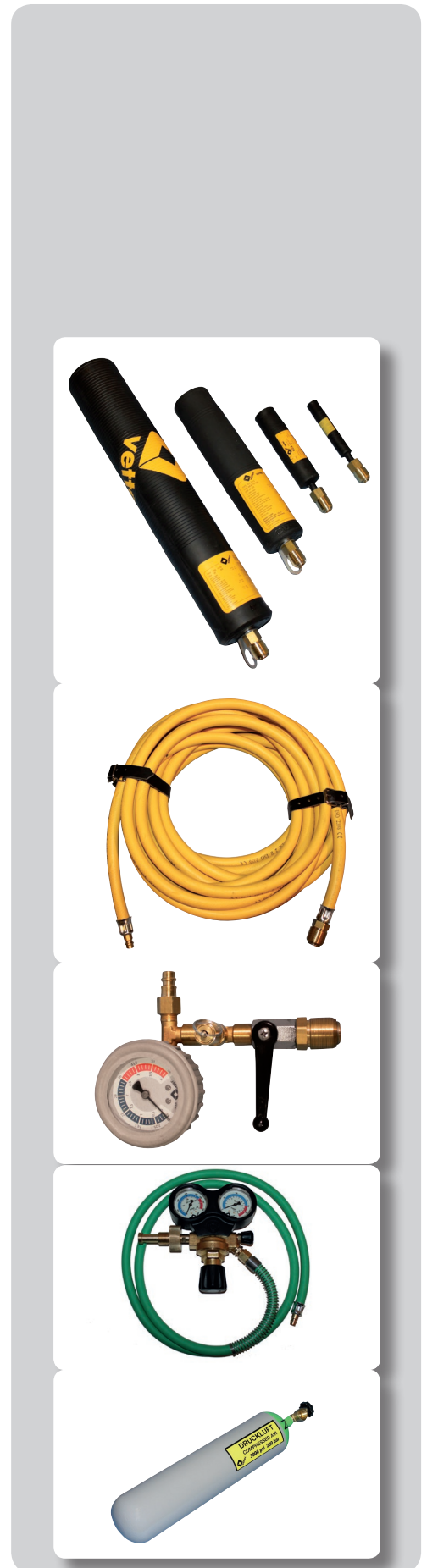

3.2 Operation with controller, inflation hose and other compressed air sources

Observe the maximum inlet pressure from the compressed air source for the different pressure levels (refer to the table below).



Applied pressure level	Maximum inlet pressure of the compressed air source
0.5 bar	2 bar
1.0 bar	2 bar
1.5 bar	2 bar
2.5 bar	4 bar

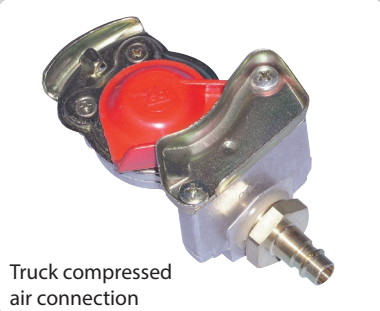

Truck compressed air connection



Dummy coupling



Adapters in the adapter set

The adapter set contains adapters for the following air sources:

Truck compressed air connection and dummy coupling

Close the control line with the dummy coupling.

Local compressed air network

Connection on the output coupling of a compressed air network.

Truck tyre valve

For inflation with a normal hand pump or foot pump

Truck tyre valve connection

For taping off air from a spare wheel.

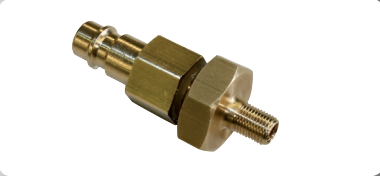

Air supply hose, 10 m with blocking valve

The air supply hose with blocking valve can be used as an extension between the air source and the controller.



Hand pump and foot pump

Hand pump or foot pump with 2 m connection hose to the connection onto the inlet coupling of a controller. Hand pump and foot pump do not belong to the delivery package of the adapter set.

3.3 Operation with a foot pump having a safety valve

Foot pump 2.5 bar with safety valve

Foot operated air pump 2.5 bar with safety valve and 2 m connection hose for inflation of sealing bags in connection with an inflation hose.

4. Operation of Pipe and Test Sealing Bags

In this chapter you will find out how the Vetter pipe and test sealing bags are applied.

When using the pipe and test sealing bags, observe the safety instructions given in chapter 2 as well as the pertinent regulations for work protection and safety protection, accident prevention regulations (e.g. the safety regulations of the technical authorities -TGB) and the generally recognized laws of technology.

4.1 Preparations for operation

- ✓ Ensure that only authorized staff are in the working area and danger area.
- ✓ Select a suitable pipe and/or test sealing bag which corresponds to the requirements.
- ✓ Check the bag and the accessories to be used for completeness and damage.
- ✓ Damaged bags and damaged accessory parts must not be used!
- ✓ The bag diameter must be smaller than the inside diameter of the pipeline.
- ✓ Inflation hose and controller must already be connected to the sealing bag.
- ✓ Mark the working area.
- ✓ Position the bag (full length) into the pipe.
- ✓ The sealing bag in the pipe is to be supported.
- ✓ Draw the sealing bag to the support structure and inflate so that it can still be moved in the pipeline.

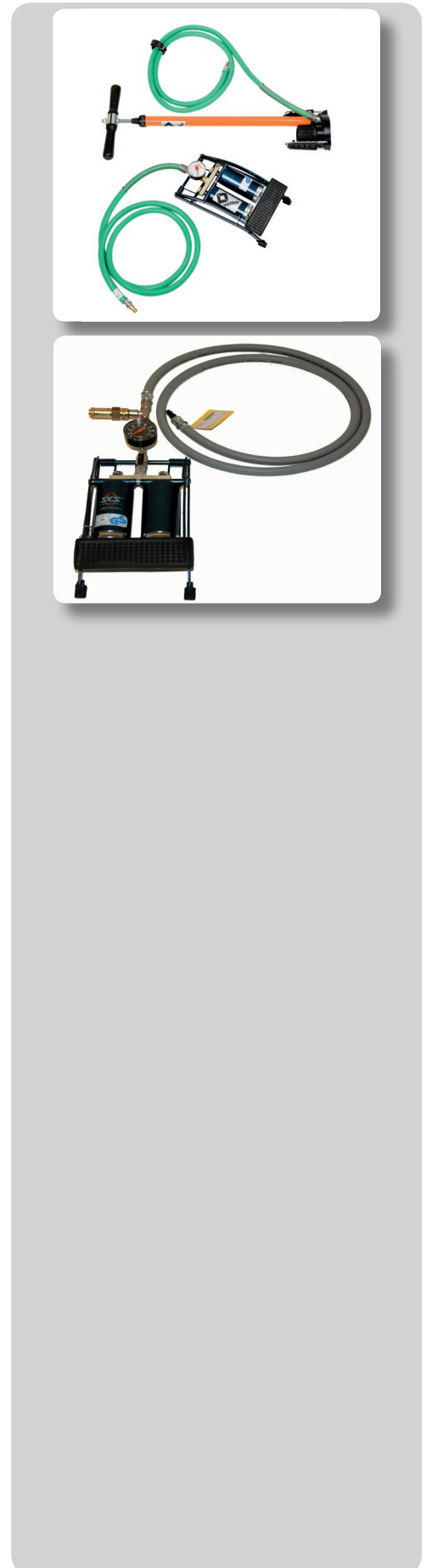



- ✓ The support structure should be made so that the sealing bag can be supported over a large area.
- ✓ Leave the shaft and/or pipeline.
- ✓ Make certain that no staff remain in the area of danger.
- ✓ Inflate the sealing bag to the permitted maximum operating pressure from a safe position.

There is a danger of the bag catapulting outwards. The pressure or water column must be completely reduced within the pipeline before the support structure is removed. Otherwise the sealing bag could catapult outwards.

After completion of the work, pressure reduction is to be carried out via the inflation hose (ventilation nipple) or the controller (pressure reduction via the knurled screw of the safety valve).

Generally this must be made outside the pipeline or shaft.

- ✓ If the water has completely flowed out of the shaft / pipeline then release the compressed air out of the bag.
- ✓ Now remove the support structure and take the bag out of the shaft/ pipeline.

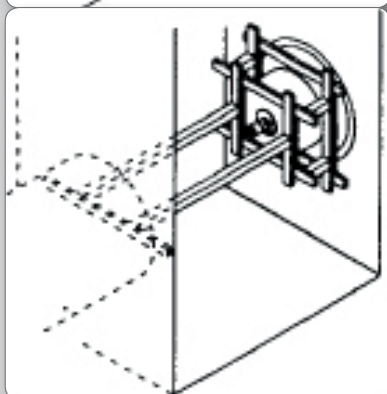
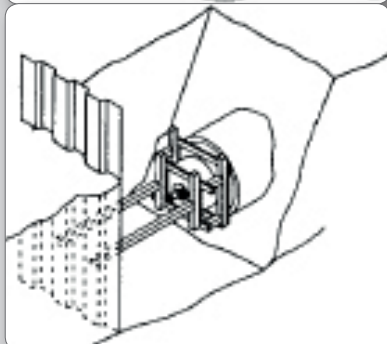
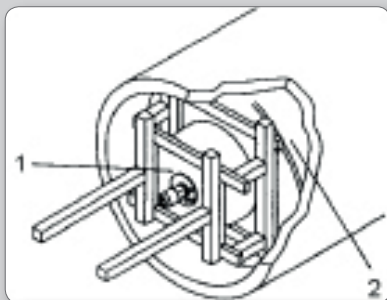

4.2 Support structure

The type of support structure depends on the structural factors in the pipe, the pipe itself and the counter-pressure to be expected. The following support possibilities are only drawing diagrams and are given as examples.

General details of support (presented as a diagram)

- 1 Bag centre
- 2 Inflatable bag sleeve

Support suggestion for a ditch

(presented as a diagram)

Support suggestion for a street inlet shaft

(presented as a diagram)

Support suggestion for a pipe opening on the outside wall (presented as a diagram)

1 Outside wall with pipe opening

4.3 Blocking a pipeline

The support structure of a pipeline under pressure must never be removed. Pipe sealing bags and test sealing bags could suddenly catapult outwards. During a pressure test nobody is permitted to remain in the shafts or on and in the pipelines under pressure.

- ✓ Vetter pipe sealing bags are used in different pipe diameters (refer to the marking on the sealing bags).
- ✓ Select pipe sealing bag, inflation hose, controller and air source.
- ✓ There must be no branches, house connections or similar things in the pipe area to be blocked.
- ✓ Connect pipe sealing bags to the inflation hose and controller and position in the pipe.
- ✓ Inflate the pipe sealing bag to the permitted maximum operating pressure from a safe position.
- ✓ If a pipeline has to be blocked with a pipe sealing bag or test sealing bag then the operating pressure is to be monitored with the controller (e.g. possible pressure changes caused by deviations in temperature).

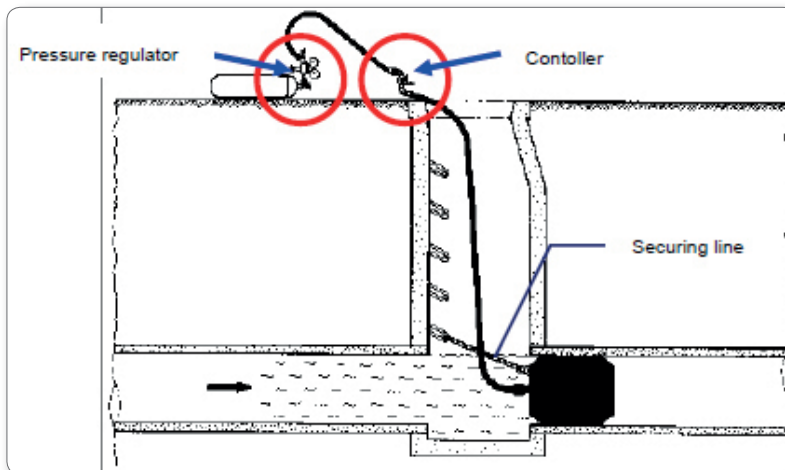

Due to presentation reasons, the support structure is schematically presented and simplified.

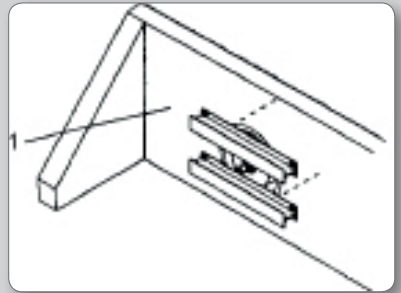

4.4 Emptying the pipeline

- ✓ It is to be ensured that nobody remains in the shaft or pipe before emptying the pipeline.
- ✓ Empty the secured sealing bag via the controller so the dammed liquid is able to slowly flow pass the sealing bag and support structure.
- ✓ The support structure or the securing device must only be removed when the pipeline is completely empty.

4.5 Water test and compressed air test

- ✓ The data specified in EN 1610 (leak testing) is to be observed concerning open channels.
- ✓ Using suitable measures, the pipe and test sealing bags are to be secured against catapulting outwards and slipping.
- ✓ Select the suitable pipe and test sealing bags depending on the pipe diameter.
- ✓ Filling the pipeline as well as ventilation and measurement of the test pressure are carried out via the test sealing bag.
- ✓ Blocking is made with the pipe sealing bag

4.6 Water pressure test (open channel)

- ✓ Insert the pipe sealing bag and test sealing bag, including assembled ventilation swimmer hose, Storz couplings and blocking valve, into the pipeline, construct the support and inflate to the permitted operating pressure with the controller and the inflation hose.
- ✓ Mount the inflation hose on the blocking valve for water filling and connect the test and measurement hose to the second Storz connection and position it vertically upwards out of the shaft.
- ✓ Attach the marking for the required height of the water column.
- ✓ Filling the pipeline takes place outside the shaft.
- ✓ The test specifications valid at the time of testing are to be observed (e.g. EN 1610).
- ✓ The pipe and test sealing bags are emptied via their inflation devices after completion of the water pressure test and complete pressure relief of the pipeline and are then removed out of the pipeline.
- ✓ This also applies to the support structure.
- ✓ Check the applied bags and their accessories for completeness, perfect condition and function.

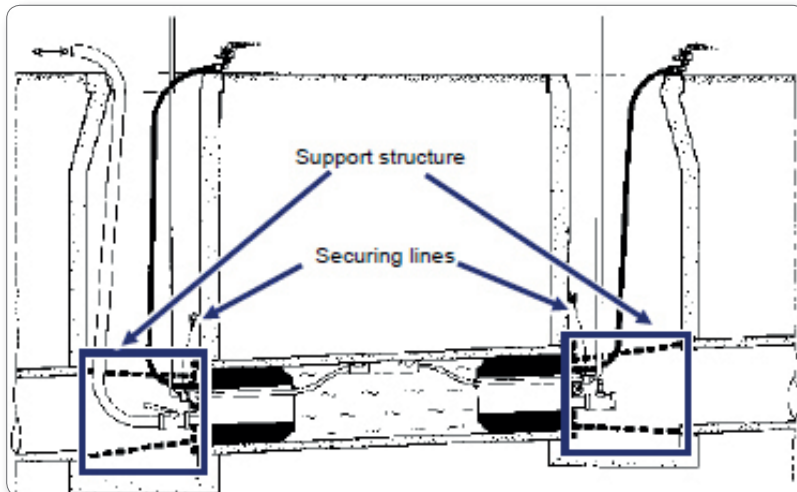

4.8 Compressed air test

The support structure of a pipeline under pressure must never be removed. Pipe sealing bags and test sealing bags could suddenly catapult outwards. During a pressure test nobody is permitted to remain in the shafts or on and in the pipelines under pressure.

- ✓ Insert pipe sealing bag and test sealing bag, including mounted compressed air adapter, into the pipeline and inflate to the permitted operating pressure with the controller and the inflation hose.
- ✓ Connect the inflation and safety hose (0.3 bar) (filling the pipeline to the permitted test pressure) and the measurement hose (0.3 bar) or, as an example, the measurement hose of the Vetter manual pressure measurement gauge, to the test adapter of the test sealing bag.
- ✓ The filling of the pipeline to be tested with the pre-specified permitted test pressure is made outside of the shaft.
- ✓ The testing time is dependent on the pre-specified test method.
- ✓ The applied pipe and test sealing bag can be deflated via their inflation fittings and taken out of the pipeline after completion of the pressure test and after complete pressure relief of the pipeline.
- ✓ Check the applied bags and their accessories after use for completeness, perfect condition and function.



 **DANGER**

4.9 Construction of a temporary bypass

Persons can be endangered by sudden intrushes of water, therefore an additional pipe sealing bag (2) must be installed in order to ensure the safety of the construction area. The safety regulations and information issued by the corresponding authorities are to be observed!

Construction of a temporary bypass (schematic diagram)

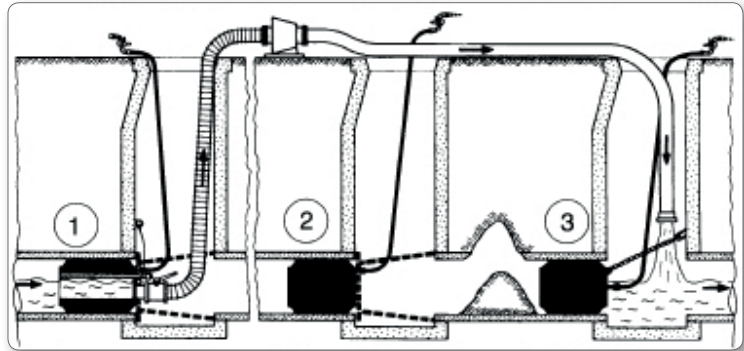

Due to presentation reasons, the support structure and securing lines are schematically presented and simplified.

- ✓ Fit the corresponding bypass adapter in order to bypass the sealing bag.
- ✓ Insert the bypass bag (1) at the top of the construction site into the pipe.
- ✓ Support the bag according to shape.
- ✓ Connect the Storz coupling (A resp. B) to the suction pump installed above ground via the suction hose.
- ✓ Make certain that the level of dammed liquid does not exceed 5m water column.
- ✓ Connect a hose to the pump on the pressure side and position it into the pipe system at the back of the construction site.
- ✓ Insert an additional pipe sealing bag (3) in order to avoid a backflow into the construction area.

5. Care, maintenance and storage

This chapter gives you information about care of your Vetter pipe and test sealing bag and the maintenance intervals which must be observed.

5.1 Care

The sealing bag equipment is to be cleaned after each operation. Cleaning is normally carried out with warm water and a detergent.

Cleaning must never be carried out with a chemical cleaning agent and never with high-pressure hot water devices.

Drying is made at normal room temperature.



CAUTION

5.2 Maintenance intervals

A function test of the safety valve must only be carried out **without** the pipe and test sealing bag. Maximum pressure area!

A function test of the safety valve **with** the pipe and test sealing bag outside the pipeline or test pipe can cause bursting of the bag.

The function test of the pipe and test sealing bag at the maximum operating pressure in the permitted maximum pipe diameter must only be carried out in a resistive pipe. A pipe which is too weak will explode when a bag is inflated to the maximum operating pressure!

CAUTION

When?	What?	What is to be done?	Who?
Before each use	Pipe and test sealing bags along with controllers and inflation hoses (Safety equipment)	check for completeness Visual check of the pipe and test sealing bags plus the safety equipment (e.g., changes in form, cracks, fabric damage, porous surfaces, etc.) Function check of the safety equipment	Expert*
		If there are any doubts after the visual check of the pipe and test sealing bags regarding their safety, the bags should be returned to the manufacturer for an in-depth function test .	Manufacturer
After each use	Pipe and test sealing bags along with controllers and inflation hoses (Safety equipment)	check for completeness Visual check of the pipe and test sealing bags plus the safety equipment (e.g., changes in form, cracks, fabric damage, porous surfaces, etc.) Function check of the safety equipment	Expert*
		If there are any doubts after the visual check of the pipe and test sealing bags regarding their safety, the bags should be returned to the manufacturer for an in-depth function test .	Manufacturer
At least once annually <i>(otherwise, according to BGI 802, it is no longer permitted to use the bags)</i>	Pipe and test sealing bags along with controllers and inflation hoses (Safety equipment)	check for completeness Visual check of the pipe and test sealing bags plus the safety equipment (e.g., changes in form, cracks, fabric damage, porous surfaces, etc.) Function check of the safety equipment	Expert*
		If there are any doubts after the visual check of the pipe and test sealing bags regarding their safety, the bags should be returned to the manufacturer for an in-depth function test .	Manufacturer

If any kind of doubts concerning the safety arise during the visual check or function check, abort the test and send the bag including the equipment to the manufacturer for further testing.

* An expert is a person who, based on his technical training and experience, has sufficient knowledge in the sector of pipe-sealing devices and is so familiar with the relevant governmental occupational safety regulations, accident prevention regulations and generally accepted laws of engineering (e.g., BG rules, DIN and EN standards, technical rules from other EU member states or other contracting states of the Treaty on the European Economic Area) that he can assess the safe working condition of the pipe-sealing devices. Source: BGI 802

Document and retain the test results.

5.3 Storage

When stored and handled properly, the properties of rubber products remain nearly constant for a long period of time. However when handled improperly and under unfavourable storage conditions, their physical properties and/or service life are shortened!



Please comply with the following storage conditions:

Store in a place that is cool, dry, dust-free and moderately ventilated.

The storage temperature should be approx. 15 °C; never let it exceed 25 °C.

The temperature should also not fall below -10 °C.

If there are heating appliances and heating conductors in the storage room, they must be appropriately insulated so that the temperature of 25 °C is not exceeded. Maintain a minimum clearance between the heating appliances and the stored goods of 1 m.

Do not store rubber products in moist storage rooms. The relative humidity should be less than 65 %.

Protect the rubber products from light (direct exposure to sunlight, artificial light with high proportion of UV). The windows in the storage room need to be correspondingly darkened.

Make sure that the storage room does not contain any appliances that cause ozone.

The storage room must be free of solvents, fuels, lubricants, chemicals, acids, etc.

Store rubber products without pressure, tensile stress or similar distortions since that can promote deformations or crack development.

Some metals such as copper and manganese can also have a damaging effect on rubber products.

For more information please refer to DIN 7716.

6. VETTER Round Profiles

6.1 Vetter Mini Pipe Sealing Bags 2.5 bar

Description

Due to their design, Vetter mini pipe sealing bags 2.5 bar can be used in house connection lines, oil and petrol collectors and in front of curves.

- ✓ Connect the inflation hose to the connection coupling of the selected mini pipe sealing bag 2.5 bar and the output coupling of the controller.
- ✓ The air supply can be made by hand pump, foot pump, pressure regulator and compressed air bottle or by a local compressed air supply line, resp. by tapping air from a truck compressed air brake device.
- ✓ Another possibility is the use of a foot air pump with a 2.5 bar safety valve.
- ✓ Insert or shift the sealing bag to the selected position and inflate it to the permitted operating pressure of 2.5 bar.
- ✓ The mini pipe sealing bag must be positioned along its whole length on the pipe wall.
- ✓ Securing lines can be used for removing the pipe sealing bag after work has finished.

Technical data

Mini Pipe Sealing Bags 2.5 bar / 36.25 psi	Pipe diameter mm / inch	Diameter mm / inch	Cylinder length mm / inch	Total length mm / inch	Air requirement litres / cu. ft.	Weight, approx. kg / lbs
RDK 2.5/4 1440000101	25 - 40 0.98 - 1.6	21 0.9	115 4.5	175 7	0.7 0.02	0.15 0.33
RDK 4/7 1440000201	40 - 70 1.6 - 2.8	37 1.5	155 6.1	215 8.5	2.5 0.09	0.2 0.44
RDK 7/10 1440025900	70 - 100 2.8 - 4	68 2.7	130 5.1	175 7	6 0.21	0.4 0.88
RDK 8/15* 1440018800	80 - 150 3.1 - 5.9	72 2.8	120 4.7	170 7	11 0.39	0.4 0.88
RDK 10/15 1440010500	100 - 150 3.9 - 5.9	89 3.5	130 5.1	175 7	7 0.25	0.56 1.23
RDK 12.5/20 1440010700	125 - 200 5 - 7.8	115 4.5	150 5.9	195 7.6	30 1.06	0.76 1.68
RDK 15/20* 1440018900	150 - 200 5.9 - 7.8	90 3.5	150 5.9	195 7.6	13 0.46	0.6 1.32
RDK 15/30 1440010600	150 - 300 5.9 - 11.8	145 5.7	200 8	245 9.7	54 1.91	1.42 3.81

Standard test counterpressure of 10 m WC / 14.5 psi.

All rights reserved for technical changes within the scope of product improvement.

*with rounded tips



6.2 VETTER Mini Test Sealing Bags 2.5 bar

Description

Vetter mini test sealing bags 2.5 bar can be used for testing, sealing and bypassing with repairs and maintenance work, e.g. sealing tests, channel inspection, maintenance, repair and cleaning.

- ✓ Please observe the permitted maximum counter-pressure of 10 m water column, resp. 1 bar, when using mini test sealing bags.
- ✓ Connect the inflation hose, 2.5 bar, to the mini test sealing bags and the single controller, 2.5 bar fitting.
- ✓ Position the mini test sealing bag, along its whole length, into the pipeline and suitably secure it, e.g. with a structure support, depending on the work to be carried out.
- ✓ Inflation of the mini test sealing bag can be carried out according to chapter 4.



Technical data

Mini Test Sealing Bags 2.5 bar / 36.25 psi	Duct	Pipe diameter mm / inch	Diameter mm / inch	Cylinder length mm / inch	Total length mm / inch	Air requirement litres / cu. ft.	Weight, approx. kg / lbs
PDK 4/7 1441000701	2 x 4 mm 2 x 0.16"	40 - 70 1.6 - 2.8	37 1.5	155 6.1	250 9.8	3.5 0.12	0.4 0.9
PDK 7/10 1441043900	1/2"	70 - 100 2.7 - 4.0	68 2.7	190 7.5	340 13.4	6.0 0.02	0.4 0.9
PDK 10/15 1441035400	1/2"	100 - 150 4 - 6	90 3.5	150 5.9	300* 11.8*	2 0.07	1 2.2
PDK 15/20 1441035200	1/2"	150 - 200 5.9 - 7.8	145 5.7	195 7.7	345* 13.6*	12 0.42	2.5 5.5
PDK 20/30 1441035300	1"	200 - 300 8 - 12	185 7.2	250 9.8	410* 16*	18 0.64	4.5 9.9

* including valve connection

Standard test counterpressure of 10 m WC / 14.5 psi.

All rights reserved for technical changes within the scope of product improvement.

6.3 Vetter Pipe Sealing Bags 0.5, 1.5 and 2.5 bar

Description

Vetter pipe sealing bags 0.5, 1.5 and 2.5 bar can be used for sealing off pipelines and channelling in connection with repair work and maintenance, e.g. channel inspection, maintenance, repair, cleaning etc.

- ✓ When selecting the pipe sealing bag please observe the pressure level and the counterpressure resulting from this (refer to Technical Data).
- ✓ 0.5 bar pipe sealing bags RDK 140/170 and 170/200 cm can be folded in the deflated condition so that they can then be inserted into a standard shaft having an opening of 600 mm.
- ✓ Connect the inflation hose(s) to the pipe sealing bag and the single or double controller of the selected pressure level.
- ✓ Position the pipe sealing bag, along its whole length, into the pipeline and suitably secure it, e.g. with a structure support, depending on the work to be carried out.
- ✓ Inflation of the pipe sealing bag can be carried out according to chapter 4.



Technical data

Pipe Sealing Bags		Pipe diameter mm / inch	Diameter mm / inch	Cylinder length mm / inch	Total length mm / inch	Air requirement litres / cu. ft.	Weight, approx. kg / lbs
RDK 2.5/4 144000101	2.5 bar (36.25 psi)	25 - 40 0.98 - 1.6	21 0.9	115 4.5	175 7	0.7 0.02	0.15 0.33
RDK 4/7 144000201	2.5 bar (36.25 psi)	40 - 70 1.6 - 2.8	37 1.5	155 6.1	215 8.5	2.5 0.09	0.2 0.44
RDK 7/15 144000301	2.5 bar (36.25 psi)	70 - 150 2.8 - 6	68 2.7	300 12	345 13.6	13.3 0.47	0.5 1.1
RDK 10/20 1440011700	2.5 bar (36.25 psi)	100 - 200 4 - 8	90 3.5	250 9.8	295 11.6	25.0 0.9	0.6 1.3
RDK 15/30 1440000601	2.5 bar (36.25 psi)	150 - 300 6 - 12	145 5.7	350 13.8	395 15.6	70.0 2.5	1.4 3.1
RDK 20/40 1440020100	2.5 bar (36.25 psi)	200 - 400 8 - 16	195 7.7	650 25.6	700 27.3	224 7.9	2.8 6.2
RDK 20/50 1440016700	2.5 bar (36.25 psi)	200 - 500 8 - 20	195 7.7	750 29.3	795 31	329 11.6	4.2 9.3
RDK 30/60 1440000801	2.5 bar (36.25 psi)	300 - 600 12 - 24	295 11.6	735 28.9	780 30.7	507.5 17.9	7.4 16.3
RDK 50/100 1440028200	2.5 bar (36.25 psi)	500 - 1,000 20 - 40	450 17.7	1,110 43.7	1,155 45.6	1,987 70.2	19.5 43.0
RDK 60/120 1480001901	1.5 bar (21.75 psi)	600 - 1,200 24 - 48	580 22.8	1,320 52	1,365 53.7	2,475 87.4	27 59.5
RDK 80/140 1480006000	1.5 bar (21.75 psi)	800 - 1,400 32 - 56	785 30.9	1,810 71.3	1,855 73	3,125 110.3	55 121.3
RDK 140/170* 1400000300	0.5 bar (7.25 psi)	1,400 - 1,700 56 - 67	1,350 53.2	1,900 74.8	2,150 84.7	8,700 307.1	55 121.3
RDK 170/200* 1400000100	0.5 bar (7.25 psi)	1,700 - 2,000 67 - 80	1,620 63.8	1,900 74.8	2,300 90.6	9,000 317.7	59 130.1

RDK 2.5 bar / 36.25 psi - Test counterpressure 10 m WC / 14.50 psi

RDK 1.5 bar / 21.75 psi - Test counterpressure 5 m WC / 7.25 psi

RDK 0.5 bar / 7.25 psi - Test counterpressure 2 m WC / 2.90 psi

* Outdoors, fill the bags maximum to half the operating pressure. Protect it from solar radiation. Likewise, do not let the temperature on the bag itself exceed 55 °C.

All rights reserved for technical changes within the scope of product improvement.

6.4 Vetter Test Sealing Bags 0.5, 1.5 and 2.5 bar

Pressure test with air

PDK 60/120 with a duct and compressed air adapter 2" in a concrete pipe DN 1200 mm.

The required securing of the test bag using a structure support has been omitted for presentation reasons.



Description

Vetter test sealing bags 0.5, 1.5 and 2.5 bar can be used for testing, sealing and bypassing with repairs and maintenance work, e.g. sealing tests, channel inspection, maintenance, repair and cleaning.

- ✓ When selecting the pipe sealing bag please observe the pressure level and the counterpressure resulting from this (refer to Technical Data).
- ✓ 0.5 bar test sealing bags RDK 140/170 and 170/200 cm can be folded in the deflated condition so that they can then be inserted into a standard shaft having an opening of 600 mm.

Test sealing bags can be supplied with one or two ducts for the water test or the compressed air test. Adapters and accessories for the water test and the compressed air test can also be supplied (refer to the catalogue).

- ✓ Connect the inflation hose(s) to the test sealing bag and the single or double controller of the selected pressure level.
- ✓ Position the test sealing bag, along its whole length, into the pipeline and suitably secure it, e.g. with a structure support, depending on the work to be carried out.
- ✓ Inflation of the test sealing bag can be carried out according to chapter 4.



Technical Data

Test Sealing Bags	Pipe diameter mm / inch	Diameter mm / inch	Cylinder length mm / inch	Total length mm / inch	Air requirement litres / cu. ft.	Weight, approx. kg / lbs	
PDK 4/7 FLEX 1441000701 2 x 4 mm (2 x 0.16 inch)	2.5 bar (36.25 psi)	40 - 70 1.6 - 2.8	37 2.7	155 6.1	250 9.8	3.5 0.12	0.4 0.88
PDK 7/15 FLEX 1441001201 1 x 1/2" AG	2.5 bar (36.25 psi)	70 - 150 2.8 - 6	68 2.7	350 13.7	395 15.4	14 0.5	1.7 3.8
PDK 10/20 FLEX 1441018501 1 x 1" AG	2.5 bar (36.25 psi)	100 - 200 4 - 8	90 3.5	510 20	555 21.9	40.3 1.4	2.0 4.4
PDK 15/30 FLEX 1441022701 2 x 1" AG 1441022800 1 x 2" AG	2.5 bar (36.25 psi)	150 - 300 6 - 12	145 5.7	460 18.1	505 20	87.5 3.1	6.2 13.8
PDK 20/40 FLEX 1441040300 2 x 1" AG 1441018600 1 x 2" AG	2.5 bar (36.25 psi)	200 - 400 8 - 16	195 7.7	640 25	685 26.7	225 7.9	8.6 19
PDK 20/50 FLEX 1441031100 2 x 1" AG 1441031200 1 x 2" AG	2.5 bar (36.25 psi)	200 - 500 8 - 20	195 7.7	750 29.3	795 31	237 - 333 8.37 - 11.8	7 - 9 15.4 - 19.8
PDK 30/60 FLEX 1441023100 2 x 1" AG 1441018701 1 x 2" AG	2.5 bar (36.25 psi)	300 - 600 12 - 24	295 11.6	735 28.9	815 32.1	454 - 471 16.03 - 16.6	11 - 12 24.3 - 26.5
PDK 50/80 FLEX 1441003900 1 x 2" AG 1441003800 2 x 2" AG	2.5 bar (36.25 psi)	500 - 800 20 - 32	450 17.7	1,110 43.7	1,155 45.6	2,065 - 2,135 72.9 - 75.4	25 55.1
PDK 60/100 FLEX 1441023200 1 x 2" AG 1441023300 2 x 2" AG	2.5 bar (36.25 psi)	600 - 1,000 24 - 40	580 22.8	1,320 52	1,365 53.7	2,613 - 2,648 92.3 - 93.5	35 - 42 77.2 - 92.6
PDK 50/100 FLEX 1481003501 1 x 2" AG 1481023800 2 x 2" AG	1.5 bar (21.75 psi)	500 - 1,000 20 - 40	450 17.7	1,110 43.7	1,155 45.6	1,475 - 1,525 52.1 - 53.8	27 - 36 59.5 - 79.4
PDK 60/120 FLEX 1481009501 1 x 2" AG 1481009301 2 x 2" AG	1.5 bar (21.75 psi)	600 - 1,200 24 - 48	580 22.8	1,320 52	1,365 53.7	2,425 - 2,450 85.6 - 86.5	35 - 42 77.2 - 92.6
PDK 80/140 FLEX 1481024000 1 x 2" AG 1481023900 2 x 2" AG	1.5 bar (21.75 psi)	800 - 1,400 32 - 56	785 30.9	1,810 71.3	1,855 73	3,075 - 3,100 108.5 - 109.4	55 - 69 121.3 - 152.2
PDK 140/170 FLEX* 1401000400 1 x 2" AG 1401000300 2 x 2" AG	0.5 bar (7.25 psi)	1,400 - 1,700 56 - 67	1,350 53.2	1,900 74.8	2,150 84.7	8,670 - 8,685 306.1 - 306.6	62.5 - 70 137.8 - 154.4
PDK 170/200 FLEX* 1401000700 1 x 2" AG 1401000600 2 x 2" AG	0.5 bar (7.25 psi)	1,700 - 2,000 67 - 80	1,620 63.8	1,000 74.8	2,300 90.6	8,775 - 8,888 309.8 - 313.8	64.5 - 70 142.2 - 154.4

PDK 2.5 bar / 36.25 psi - Test counterpressure 10 m WC / 14.50 psi

PDK 1.5 bar / 21.75 psi - Test counterpressure 5 m WC / 7.25 psi

PDK 0.5 bar / 7.25 psi - Test counterpressure 2 m WC / 2.90 psi

* Outdoors, fill the bags maximum to half the operating pressure. Protect it from solar radiation. Likewise, do not let the temperature on the bag itself exceed 55 °C.

All rights reserved for technical changes within the scope of product improvement.

6.5 Vetter Bypass Bags 1.5 bar

Description

Vetter 1.5 bar bypass bags can be used for creating a bypass with defective channels. They can also be used for channel repairs and reconstruction as two-sided, temporary blocking with conduction and pressure relief from the incoming pipeline to the outgoing pipeline.

- ✓ Please observe the permitted maximum counter-pressure of 5 m water column, resp. 0.5 bar, when using bypass bags.
- ✓ Connect the inflation hose, 1.5 bar, to the bypass bag and the single controller, 1.5 bar fitting.
- ✓ Insert the bypass bag along its full length into the pipeline and secure it against catapulting out using suitable devices, e.g. a structure support.
- ✓ Inflation of the bypass bag can then be made as described in chapter 4.



Technical Data

Bypass Bags 1.5 bar / 21.75 psi	Pipe diameter <i>mm / inch</i>	Diameter <i>mm / inch</i>	Cylinder length <i>mm / inch</i>	Total length <i>mm / inch</i>	Air requirement <i>litres / cu. ft.</i>	Weight, approx. <i>kg / lbs</i>
PDK 10/20 PE core <i>1481004401 1 x 2 1/2" AG</i>	100 - 200 <i>4 - 8</i>	97 <i>3.9</i>	485 <i>19.1</i>	635 <i>25</i>	27 <i>0.95</i>	2.2 <i>4.9</i>
PDK 20/50 PE core <i>1481005001 1 x 4" AG</i>	200 - 500 <i>8 - 20</i>	195 <i>7.7</i>	550 <i>21.7</i>	700** <i>27.6</i>	143 <i>5</i>	7 <i>15.4</i>
PDK 50/80 PE core* <i>1481006900 1 x 4" AG</i>	500 - 800 <i>20 - 32</i>	450 <i>17.7</i>	565 <i>22.2</i>	720** <i>28.3</i>	310 <i>10.9</i>	23,5 <i>50,8</i>
PDK 50/120 PE core* <i>1481008000 1 x 4" AG</i>	500 - 1,200 <i>20 - 48</i>	450 <i>17.7</i>	940 <i>37</i>	1.070** <i>42.1</i>	1,420 <i>50.1</i>	36,8 <i>81,1</i>

* A 6" or 8" duct can be supplied when required.

** including valve connection

Standard test counterpressure of 5 m WC / 7.25 psi.

All rights reserved for technical changes within the scope of product improvement.

Set 10/20 FLEX for water pressure testing and compressed air testing



6.6 Vetter House connection Testing system 2.5 bar

Description

Vetter house connection systems are used for leak testing of house connections. Blocking work and the test sequence are normally carried out from the inspection shaft or from the inspection opening.

- ✓ The pipe test sealing bag is pushed through the pipeline up to the main channel using the thrust hose.
- ✓ Inflation of the pipe sealing bag is made by the foot operated air pump 2.5 bar which is contained in the set.
- ✓ The test sealing bag is then positioned at the exit side of the inspection shaft or the inspection opening and is also inflated with the foot operated air pump 2.5 bar.
- ✓ The safety valve on the foot operated air pump avoids any unintentional overinflation above the permitted operating pressure.
- ✓ The thrust hose is pulled tight after checking for a firm seating of the test sealing bag and is sealed by tightening the union nut with the appropriate spanner.

The test set 10/20 Flex can be used for the compressed air test as well as the water pressure test. With this set there is an additional tapered head mounted on the thrust hose in front of the pipe sealing bag which enables retraction of the inserted pipe sealing bag even over sleeve displacements.

A blocking valve with a bayonet coupling for inflation, an adapter and a test and measurement hose are supplied for water pressure testing.

The compressed air test can be carried out with the supplied accessories according to the requirements specified in EN 1610.

Technical Data

House connection Testing system 2.5 bar / 36.25 psi	Pipe diameter mm / inch	Diameter mm / inch	Cylinder length mm / inch	Total length mm / inch	Air requirement litres / cu. ft.	Weight, approx. kg / lbs
RDK 8/15 1440001200	80 - 150 3.1 - 6	72 2.8	120 4.7	165 6.5	11 0.39	0.3 0.7
RDK 15/20 1440001300	150 - 200 6 - 8	90 3.5	150 5.9	190 7.4	13 0.46	0.5 1.1
PDK 10/20 FLEX 1441007703	100 - 200 4 - 8	90 3.5	300 11.8	460* 18*	18 0.54	3.1 6.8

* incl. valve connection

Standard test counterpressure of 10 m WC / 14.5 psi.

All rights reserved for technical changes within the scope of product improvement.

6.7 Vetter Test Sealing Bags for Gullies 1,0 bar

Description

Vetter shaft testing bags are used to test shafts. They feature short, light construction that makes them easy to handle. For more information on testing, please see the current version of DIN EN 1610.

Adapters and accessories for water and compressed air testing are also available (see catalogue).

- ✓ Connect the filling hose with the shaft testing bag and the 1.0 single-control element.
- ✓ Put the shaft testing bag into the pipeline and secure it, depending on the work to be performed, with suitable means such as a bracing.
- ✓ You can then fill the shaft testing bag as described in Chapter 4.

Technical Data

Test Sealing Bags for Gullies	Pipe diameter mm / inch	Diameter mm / inch	Height mm / inch	Bypass Ø	Weight, approx. kg / lbs	Pressure bar / psi
TSG 600-650 1411002300	600 - 650 23,6 - 25.6	450 17.7	300 11.8	2"	11.6 25.6	1 14.5

Standard test counterpressure of 0.2 bar / 2.9 psi.

Outdoors, fill the bags maximum to half the operating pressure. Protect it from solar radiation. Likewise, do not let the temperature on the bag itself exceed 55 °C.

All rights reserved for technical changes within the scope of product improvement.



6.8 Vetter Pipe Sealing Bags CR

Description

Vetter pipe sealing bags CR can be floated into the pipeline with the liquid flow. The material ensures good resistance against chemicals.

- ✓ Connect the inflation hose(s) to the pipe sealing bag CR and the single or double controller of the selected pressure level.
- ✓ Attach the spring hooks of the securing lines to the securing lugs.
- ✓ Position the pipe sealing bag CR in the direction of flow into a shaft and let it float with the liquid flow into the pipe.
- ✓ In doing this, observe the selected diameter and the buoyancy of the sealing bag.
- ✓ When the sealing bag has been floated in to its full length then inflation can begin as described in chapter 4.
- ✓ The pipe sealing bag CR is to be fastened during the float-in procedure and the inflation sequence.
- ✓ Final securing of the bag is only made when the permitted maximum operating pressure is reached.



Technical Data

Pipe Sealing Bag CR	Pipe diameter mm / inch	Diameter mm / inch	Cylinder length mm / inch	Total length mm / inch	Air requirement litres / cu. ft.	Weight, approx. kg / lbs	
RDK 7/15 1440008100	2,5 bar (36,25 psi)	70 - 150 3 - 6	68 2,7	300 11,8	345 13,4	14 0,5	0,6 1,3
RDK 10/20 1440024300	2,5 bar (36,25 psi)	100 - 200 3,9 - 7,9	90 3,5	250 9,8	295 11,6	25,0 0,9	0,6 1,3
RDK 15/30 1440008000	2,5 bar (36,25 psi)	150 - 300 6 - 12	145 5,7	350 13,8	395 15,6	70,0 2,5	1,4 3,1
RDK 20/40 1440027100	2,5 bar (36,25 psi)	200-400 7,9 - 15,7	195 7,7	650 25,6	700 27,6	224 8,8	3,4 7,5
RDK 30/60 1440007900	2,5 bar (36,25 psi)	300 - 600 12 - 24	295 11,6	735 29	780 30,4	508 18	7,3 16,1
RDK 60/120 1480004800	1,5 bar (21,75 psi)	600 - 1.200 24 - 48	580 22,8	1.320 52	1.365 53,7	2.475 87,4	27 59,5

RDK 2.5 bar / 36.25 psi - Test counter pressure 10 m WC / 14.50 psi

RDK 1.5 bar / 21.75 psi - Test counter pressure 5 m WC / 7.25 psi

All rights reserved for technical changes within the scope of product improvement.

6.9 Vetter High Pressure Pipe Sealing Bags 6 bar

Description

Vetter high pressure pipe sealing bags 6 bar can be used in pipelines having a high internal pressure. These pipe sealing bags can be used up to a counter-pressure of maximum 30 m water column, resp. 3 bar.

The high pressure pipe sealing bag must be positioned along its whole length on the pipe wall and be secured against catapulting outwards using suitable means (e.g. support structure).

A pipeline can burst!

It is imperative that the resistance of the pipeline be tested before using the high pressure pipe sealing bag due to the fact that the sealing bag produces a maximum area pressure of 6 kg/cm².

- ✓ Connect the inflation hose to the pipe sealing bag and then to the controller 6 bar (a double controller 6 bar with two inflation hoses can be used from DN 500 mm onwards).
- ✓ Check for perfect locking of the nipple into the coupling.
- ✓ The air supply can then be turned on (as described in chapter 4).
- ✓ Insert the high pressure pipe sealing bag into the pipeline.
- ✓ Inflate the high pressure pipe sealing bag with controller and inflation hose until the permitted operating pressure of maximum 6 bar is reached.

Technical Data

High Pressure Pipe Sealing Bags	Pipe diameter mm / inch	Diameter mm / inch	Cylinder length mm / inch	Total length mm / inch	Air requirement litres / cu. ft.	Weight, approx. kg / lbs
RDK 100-200 1430001300	100 - 200 4 - 8	90 3.5	510 20	555 21.9	105 3.7	1.5 3.3
RDK 200-300 1430001500	200 - 300 8 - 12	195 7.7	650 25.6	695 27.4	338 11.9	3.1 6.8
RDK 300-400 1430001400	300 - 400 12 - 16	295 11.6	735 29	780 30.7	527 18.6	7 15.4
RDK 500-600 1430000600	500 - 600 20 - 24	450 17.7	1,110 43.7	1,155 45.5	1,550 54.7	20 44.1
RDK 800 1430000800	800 32	785 30.9	1,810 71.3	1,855 73	6,160 217.5	44 97

Standard test counterpressure of 30 m WC / 43.5 psi.

All rights reserved for technical changes within the scope of product improvement.



Egg profile sealing bag 1 bar



Egg profile sealing bag 1.5 bar

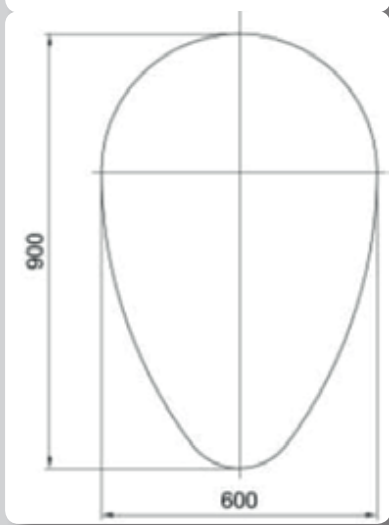

7. VETTER Egg Profiles

7.1 Vetter Egg Profile Bags 1 & 1.5 bar

Description

Vetter egg profile sealing bags 1 and 1.5 bar can be used for blocking egg-shaped pipelines and channel lines during repair and maintenance work, e.g. channel inspection, maintenance and cleaning.

- ✓ Please observe the specified sizes of egg profile bags: e.g. EDK 60/90 – the first number is the diameter in cm of the upper area of the profile, the second number gives the size of the inside height of the egg profile in cm (refer to the drawing below).
- ✓ Also please observe the permitted maximum counter-pressure of 5 m water column, resp. 0.5 bar, when using the egg profile sealing bag.

Vetter egg profile sealing bags 1 bar can be folded in the deflated condition so that they are able to be inserted through a standard shaft opening of 600 mm.

The egg profile sealing bag EDK 35/52.5 –50/75 1.5 bar can be used for a number of profile sizes.

Egg profile sealing bags 1 bar are used for the specified size.

- ✓ Connect the 1.5 bar inflation hose (plug-in nipple/coupling) or 1 bar inflation hose (claw coupling) to the connection coupling of the egg profile sealing bag 1.5 bar, resp. 1 bar, and also to the 1.5 bar, resp. 1 bar, connection nipple/coupling of the controller.
- ✓ Position the whole length of the sealing bag into the pipeline and secure it with a suitable device, e.g. with a structure support, in order to stop it from catapulting outwards.
- ✓ Inflation of the sealing bag can then be made according to description given in chapter 4.

Technical Data

Egg Profile Bags 1 & 1.5 bar		Pipe cross- section mm / inch	Cylinder length mm / inch	Total length mm / inch	Air requirement litres / cu. ft.	Weight, approx. kg / lbs
EDK 35/52.5 - 50/75 1420000101	1.5 bar (21.75 psi)	350/525 - 500/750 14/21 - 20/30	600 23.4	645 25.4	250 8.8	8 17.6
EDK 60/90* 1420000300	1 bar (14.5 psi)	600/900 23.4/35	1,200 47.2	1,400 55.1	840 29.7	17 37.5
EDK 70/105* 1420000400	1 bar (14.5 psi)	700/1,050 28/41	1,200 47.2	1,450 57.1	1,400 49.4	20 44.1
EDK 90/135* 1420000500	1 bar (14.5 psi)	900/1,350 35/53	1,800 70.2	2,200 86.6	2,640 93.2	26 57.3

Standard test counterpressure of 5 m WC / 7.25 psi

* Outdoors, fill the bags maximum to half the operating pressure. Protect it from solar radiation. Likewise, do not let the temperature on the bag itself exceed 55 °C.

All rights reserved for technical changes within the scope of product improvement.

7.2 Vetter Egg Profile Testing and Bypass bags 1 & 1.5 bar

Description

Vetter egg profile bags and bypass bags 1 and 1.5 bar can be used for blocking and bypassing when carrying out repair and maintenance work, e.g. leak testing, channel inspection, maintenance and repair as well as cleaning work.

- ✓ Please observe the permitted maximum counter-pressure of 5 m water column, resp. 0.5 bar, when using the egg profile sealing bag.

Vetter egg profile bags can be folded in the deflated condition so that they are able to be inserted through a standard shaft opening of 600 mm.

Adapters and accessories for water testing and compressed air testing can also be supplied (refer to the catalogue).

- ✓ The egg profile sealing bag and bypass bag EDK 35/52.5 –50/75, 1.5 bar, can be used for a number of profile sizes. Egg profile sealing bags 1 bar are each used for the specified size.
- ✓ Connect the 1.5 bar inflation hose (plug-in nipple/coupling) or the 1 bar inflation hose (claw coupling) to the 1.5 bar (plug-in coupling) or the 1 bar (claw coupling) connection coupling of the egg profile test bag and the connection nipple/coupling of the 1.5 bar or 1 bar controller.
- ✓ Insert the whole length of the test bag into the pipeline and secure it with a suitable device against catapulting outwards, e.g. with a structure support.
- ✓ Inflation of the test bag is then made according to the description given in chapter 4.

Egg profile base bag 1 bar



Egg profile bag 1.5 bar



Technical Data

Egg Profile Testing and Bypass bags	Pressure	Pipe cross-section mm / inch	Cylinder length mm / inch	Total length mm / inch	Air requirement litres / cu. ft.	Weight, approx. kg / lbs
EPK 35/52.5 - 50/75 1421000101 1 x 1" AG	1.5 bar (21.75 psi)	350/525 - 500/750 14/21 - 20/30	600 23.4	645 25.4	225 7.9	12 26.5
EPK 60/90* 1421001300 1 x 2" AG	1 bar (14.5 psi)	600/900 23.4/35	1,200 47.2	1,400 55.1	820 29	26 - 35 57.3 - 77.2
EPK 70/105* 1421001700 1 x 2" AG	1 bar (14.5 psi)	700/1,050 28/41	1,200 47.2	1,450 57.1	1,380 48.7	29 - 38 63.9 - 83.8
EPK 90/135* 1421002000 1 x 2" AG	1 bar (14.5 psi)	900/1,350 35/53	1,800 70.2	2,200 86.6	2,620 92.5	36 - 46 79.4 - 101.4

Standard test counterpressure of 5 m WC / 7.25 psi

* Outdoors, fill the bags maximum to half the operating pressure. Protect it from solar radiation. Likewise, do not let the temperature on the bag itself exceed 55 °C.

All rights reserved for technical changes within the scope of product improvement.

8. Counter-pressure tables

Measured in dry metal pipe.

All counter-pressure specifications in bar (psi).

Mini Pipe Sealing Bags 2.5 bar (36.25 psi)

Diameter mm / inch	RDK 2,5/4 1440000101	RDK 4/7 1440000201	RDK 7/10 1440025900	RDK 8/15 1440018800	RDK 10/15 1440010500	RDK 12,5/20 1440010700	RDK 15/20 1440018900	RDK 15/30 1440010600
25 / 1	1.6 / 23.9							
40 / 1.6	1.4 / 20.3	1.65 / 23.9						
50 / 2		1.5 / 21.8						
70 / 2.8		1.25 / 18.1	1.5 / 21.8					
80 / 3.1			1.3 / 18.9	1.35 / 19.6				
90 / 3.5			1.3 / 18.9	1.25 / 18.1				
100 / 4			1.3 / 18.9	1.25 / 18.1	1.4 / 20.3			
125 / 5				1.25 / 18.1	1.35 / 19.6		1.4 / 10.3	
150 / 6				1.05 / 15.2	1.3 / 18.9	1.15 / 16.7	1.3 / 18.9	1.35 / 19.6
200 / 8						1.1 / 15.9	1.25 / 18.1	1.3 / 18.9
250 / 10								1.25 / 18.1
300 / 12								1.25 / 18.1

Mini Test Sealing Bags 2.5 bar (36.25 psi)

Diameter mm / inch	PDK 4/7 1441000701	PDK 7/10 1441043900	PDK 10/ 15 1441035400	PDK 15/20 1441035200	PDK 20/30 1441035300
40 / 1.6	1.8 / 26.1				
50 / 2	1.6 / 23.2				
70 / 2.8	1.3 / 18.9	1.3 / 18.9			
80 / 3.1		1.3 / 18.9			
90 / 3.5		1.3 / 18.9			
100 / 4		1.3 / 18.9	1.5 / 21.8		
125 / 5			1.25 / 18.1		
150 / 6			1.2 / 17.4	1.3 / 18.9	
200 / 8				1.2 / 17.3	1.25 / 18.1
250 / 10					1.2 / 17.4
300 / 12					1.15 / 16.7

High Pressure Pipe Sealing Bags 6 bar (87 psi)

Diameter mm / inch	RDK 100-200 1430001300	RDK 200-300 1430001500	RDK 300-400 1430001400	RDK 500-600 1430001600	RDK 800 1430000800
100 / 4	3.7 / 53.6				
125 / 5	3.6 / 52.2				
150 / 6	4.6 / 66.7				
200 / 8	3.3 / 47.9	4.75 / 68.9			
250 / 10		4 / 58			
300 / 12		3.4 / 49.3	3.8 / 55.1		
400 / 16			3.6 / 52.2		
500 / 20				4 / 58	
600 / 24				3.4 / 49.3	
800 / 32					3 / 43.5

All counter-pressure specifications in bar (psi).

Pipe Sealing Bags							
Dia-meter mm / inch	RDK 7/15 1440000301 1440008100 (CR)	RDK 10/20 1440011700 1440024300 (CR)	RDK 15/30 1440000601 1440008000 (CR)	RDK 20/40 1440020100 1440027100 (CR)	RDK 20/50 1440016700	RDK 30/60 1440000801 1440007900 (CR)	RDK 50/100 1440028200
2,5 bar (36.25 psi)							
70 / 2.8	2.1 / 30.5						
80 / 3.1	2 / 29						
90 / 3.5	1.8 / 26.1						
100 / 4	1.7 / 24.7	2.4 / 35					
125 / 5	1.6 / 23.2	2.0 / 22.9					
150 / 6	1.1 / 16	1.85 / 26.8	2.4 / 35				
200 / 8		1.3 / 18.9	2.1 / 30.5	2.3 / 33.4	2.2 / 31.9		
250 / 10			1.5 / 21.8	2.3 / 33.4	2 / 29		
300 / 12			1.0 / 14.5	2.1 / 30.5	2 / 29	2.3 / 33.4	
400 / 16				1.9 / 28	1.9 / 28	2 / 29	
500 / 20					1.7 / 24.7	1.9 / 28	
600 / 24						1.6 / 23.2	
800 / 32							
1000 / 40							1.44 / 20.9

Pipe Sealing Bags				
Diameter mm / inch	RDK 60/120 1480001901 1480004800 (CR)	RDK 80/140 1480006000	RDK 140/170 1400000300	RDK 170/200 1400000100
1,5 bar (21.75 psi)		0,5 bar (7.25 psi)		
500 / 20				
600 / 24	1.1 / 16			
800 / 32	0.95 / 13.8	0.5 / 7.3		
1000 / 40	0.85 / 12.3	0.5 / 7.3		
1200 / 48	0.75 / 10.9	0.5 / 7.3		
1400 / 56		0.5 / 7.3	0.2 / 2.9	
1700 / 67			0.2 / 2.9	0.2 / 2.9
2000 / 80			0.2 / 2.9	0.2 / 2.9

All counter-pressure specifications in bar (psi).

Test Sealing Bags

Diameter mm / inch	PDK 4/7 FLEX 1441000701	PDK 7/15 FLEX 1441001201	PDK 10/20 FLEX 1441018501	PDK 15/30 FLEX 1441022701 1441022800	PDK 20/40 FLEX 1441040300 1441018600	PDK 20/50 FLEX 1441031100 1441031200	PDK 30/60 FLEX 1441023100 1441018701	PDK 50/80 FLEX 1441003900 1441003800
2,5 bar (36.25 psi)								
40 / 1.6	1.3 / 18.9							
70 / 2.8	1.3 / 18.9	1.55 / 22.5						
80 / 3.1		1.75 / 25.4						
90 / 3.5		1.7 / 24.7						
100 / 4		1.65 / 23.9	1.6 / 23.2					
125 / 5		1.5 / 21.8	1.5 / 21.8					
150 / 6		1.4 / 20.3	1.4 / 20.3	1.65 / 23.9				
200 / 8			1.45 / 21	1.6 / 23.2	1.45 / 21	2 / 29		
250 / 10				1.5 / 21.8	1.3 / 18.9	1.7 / 24.7		
300 / 12				1.3 / 18.9	1.35 / 19.6	1.65 / 23.9	1.6 / 23.2	
400 / 16					1.3 / 18.9	1.5 / 21.8	1.65 / 23.9	
500 / 20						1.35 / 19.6	1.4 / 20.3	1.4 / 20.3
600 / 24							1.3 / 18.9	1.5 / 21.7
800 / 32								1.35 / 19.6

Test Sealing Bags

Diameter mm / inch	PDK 60/100 FLEX 1441023200 1441023300	PDK 50/100 FLEX 1481003501 1481023800	PDK 60/120 FLEX 1481009501 1481009301	PDK 80/140 FLEX 1481024000 1481023900	PDK 140/170 FLEX 1401000400 1401000300	PDK 170/200 FLEX 1401000700 1401000600
	2,5 bar (36.25 psi)	1,5 bar (21.75 psi)			0,5 bar (7.25 psi)	
500 / 24		1.2 / 17.4				
600 / 24	1.75 / 25.4	1.2 / 17.4	1.05 / 15.2			
800 / 32	1.5 / 21.8	1 / 14.5	0.9 / 13.1	0.5 / 7.3		
1000 / 40	1.3 / 18.9	0.55 / 8	0.8 / 11.6	0.5 / 7.3		
1200 / 48			0.75 / 10.9	0.5 / 7.3		
1400 / 56				0.5 / 7.3	0.2 / 2.9	
1700 / 67					0.2 / 2.9	0.2 / 2.9
2000 / 80					0.2 / 2.9	0.2 / 2.9

9. Material and resistance charts

9.1 Material list

Products	Material	Support material	Manufacturing process
Mini pipe sealing bag			
High pressure pipe sealing bag	NR	Nylon cord	Hot vulcanised
Egg profile sealing bag 1.5 bar			
Egg profile test sealing bag 1.5 bar			
Mini test sealing bag	NR	NR	Hot vulcanised
Pipe sealing bag 1.5 bar			
Pipe sealing bag 2.5 bar			
Test sealing bag 1.5 bar	NR	Nylon cord / Aramide	Hot vulcanised
Test sealing bag 2.5 bar			
Bypass bag 1.5 bar			
Pipe sealing bag 0.5 bar			
Test sealing bag 0.5 bar			
Egg profile sealing bag 1 bar	CR/NR	Nylon cord / Aramid	Hot/Cold vulcanised
Egg profile test sealing bag 1 bar			
Egg profile bypass bag 1 bar			
Pipe sealing bag CR	CR	Nylon cord	Hot vulcanised
Test sealing bag for gullies 1 bar			
Inflation and air supply hoses	EPDM	Polyester	-

9.2 Temperature resistance

Products	Cold resistance	Cold flexibility	Heat resistance long term	Heat resistance short term
Mini pipe sealing bags				
Mini test sealing bags				
Pipe sealing bag 1.5 bar				
Pipe sealing bag 2.5 bar				
Test sealing bag 1.5 bar				
Test sealing bag 2.5 bar				
Bypass bag 1.5 bar	- 40 °C	- 20 °C	+ 90 °C	+ 115 °C
Pipe sealing bag CR				
High pressure pipe sealing bag				
Test sealing bag for gullies 1 bar				
Egg profile sealing bag 1.5 bar				
Egg profile test sealing bag 1.5 bar				
Pipe sealing bag 0.5 bar				
Test sealing bag 0.5 bar				
Egg profile sealing bag 1 bar	- 40 °C	- 20 °C	+ 55 °C	--
Egg profile test sealing bag 1 bar				
Egg profile bypass bag 1 bar				
Rubber hoses	- 40 °C	- 30 °C	+ 90 °C	--
Controllers:				
Plastic, aluminium and fitting construction type	- 20 °C	--	+ 55 °C	--

9.3 Resistance chart

Description of material	CR	Material	
		NR	EPDM
Acetone	o	+	-
Acetylene	+	+	-
Alum watery	+	+	-
Aluminum chloride	+	+	+
Aniline	-	n.d.	n.d.
ASTM Oil 1	o	-	-
Petrol	o	-	n.d.
Benzene	-	-	-
Boric acid	+	+	+
Bromine (moist)	-	-	-
Butyric acid	-	-	n.d.
Chlorine gas (moist)	-	-	n.d.
Chorine, wet	o	-	o
Diesel fuel	o	-	-
Iron chloride	+	+	+
Crude oil	o	-	-
Acetic acid	o	+	o
Fatty acid	+	o	-
Formaldehyde	+	+	+
Glucose	+	+	+
Heating oil	+	-	-
Potassium chloride	+	+	+
Calcium chloride	+	+	+
Calcium nitrate	+	+	+
Carbon dioxide	+	+	+
Carbon monoxide	+	+	+
Copper sulphate	+	+	+
Adhesive	+	+	+
Methyl chloride	-	-	o
Sea water	+	+	n.d.
Mineral oil	+	-	-
Sodium carbonate	+	+	-
Ozone	+	-	+
Paraffin	+	-	-
Perchloric acid	o	n.d.	+
Phenol (watery)	-	-	+
Phosphoric acid (concentrated)	-	-	-
Mercury	+	+	+
Nitric acid (fuming)	-	-	-
Sulphur dioxide (dry)	-	o	n.d.
Sulphuric acid (50%)	+	-	-
Nitrogen	+	+	+
Carbon tetrachloride	-	-	-
Animal fat	+	-	+
Toluene	-	-	-

+ resistant 0 conditionally resistant - non-resistant n.d. no details

Place your trust in emergency pneumatics!

We are the company who can help you, find a solution to your problem!

Vetter GmbH

A Unit of IDEX Corporation

Sales

Blatzheimer Str. 10 - 12
D-53909 Zülpich
Germany

Tel.: +49 (0) 22 52 / 30 08-0
Fax: +49 (0) 22 52 / 30 08-690
Mail: vetter.water@idexcorp.com

www.vetter.de